

VC3330

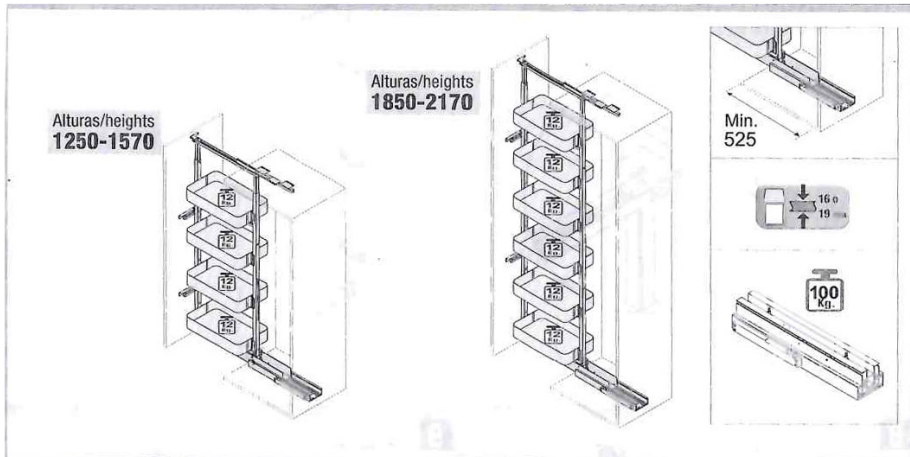

Componentes / Components

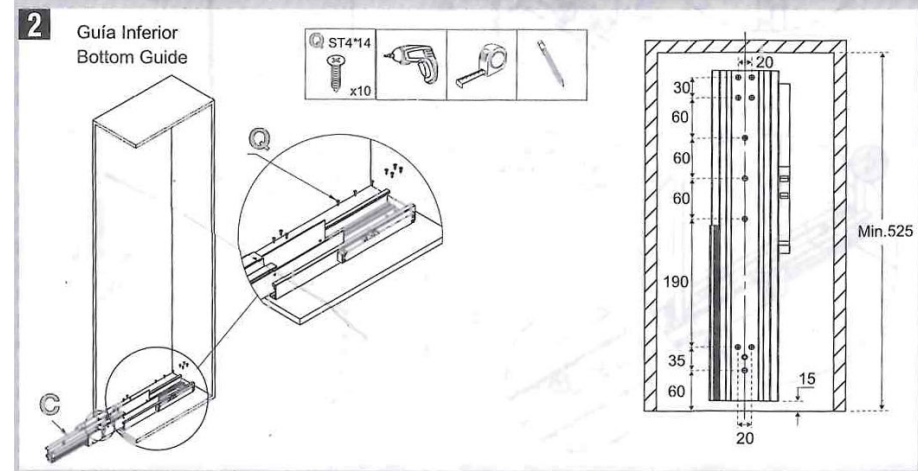

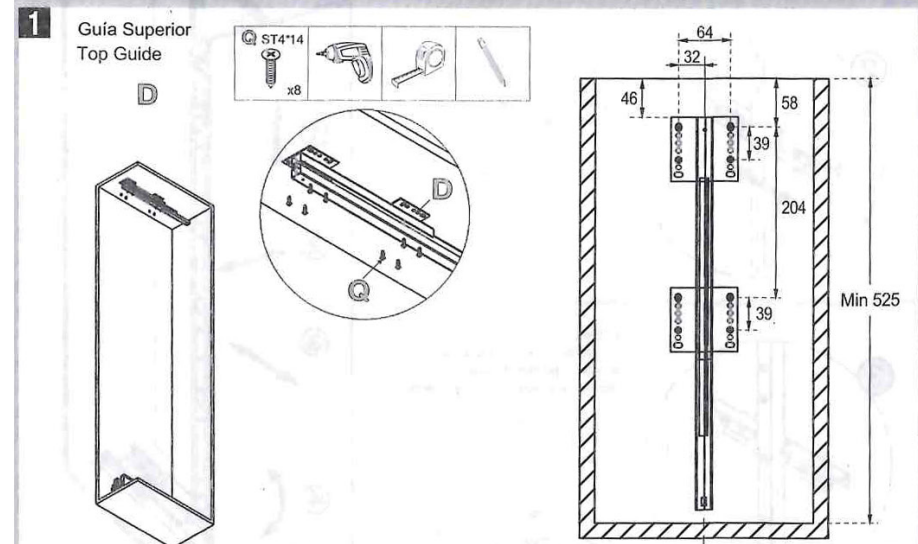
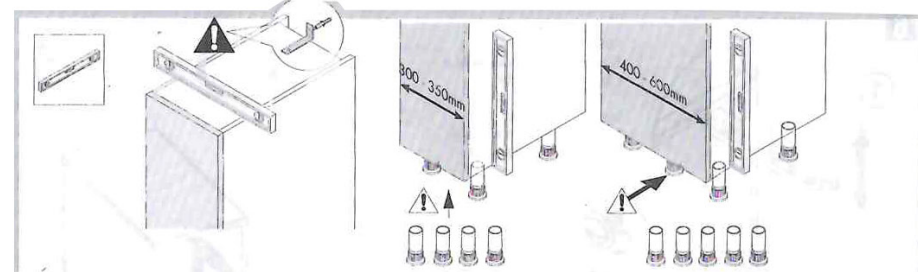
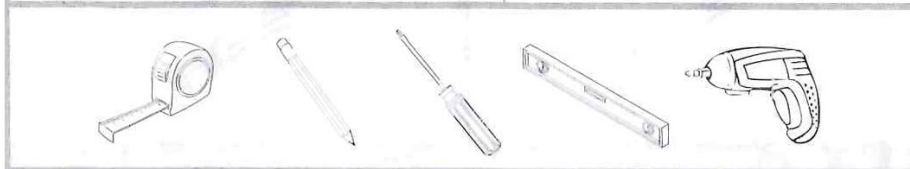
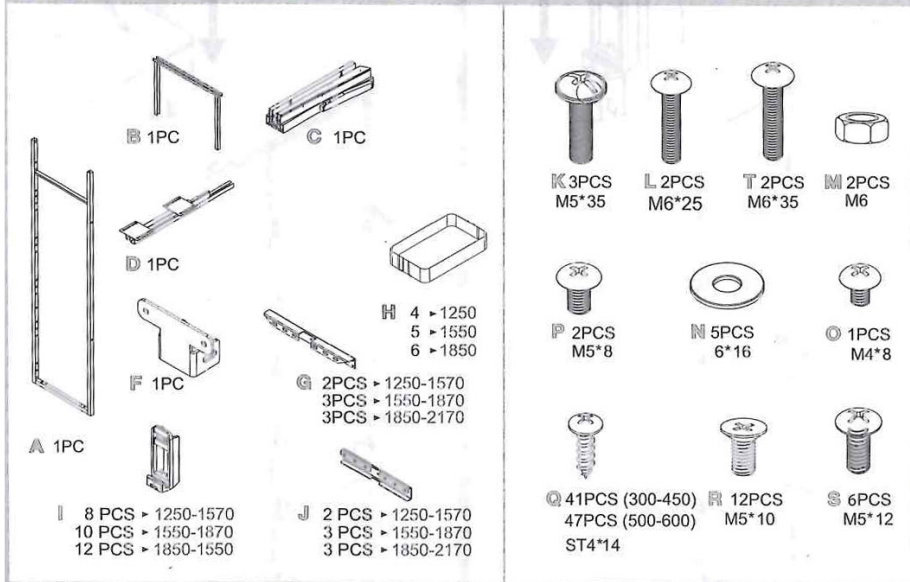
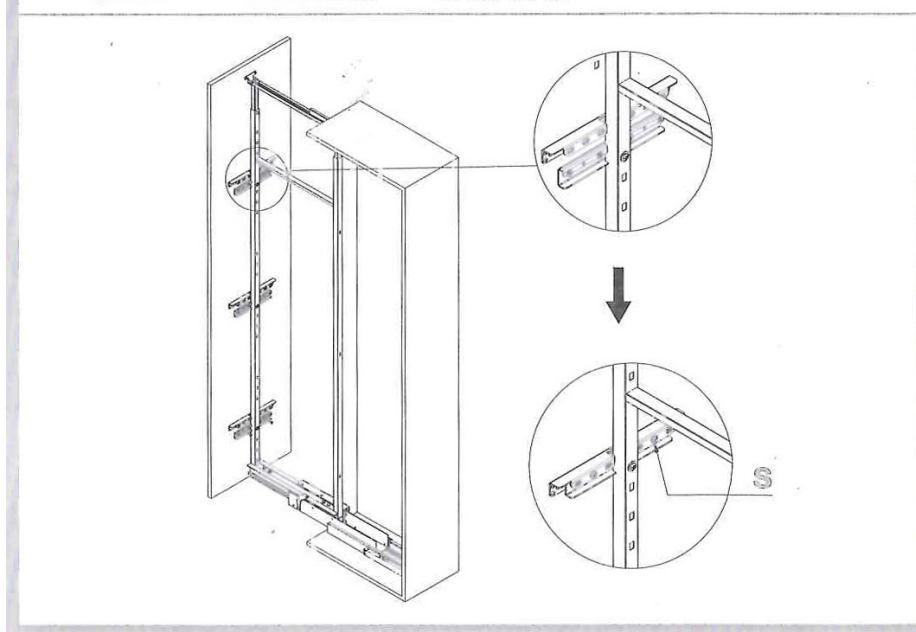
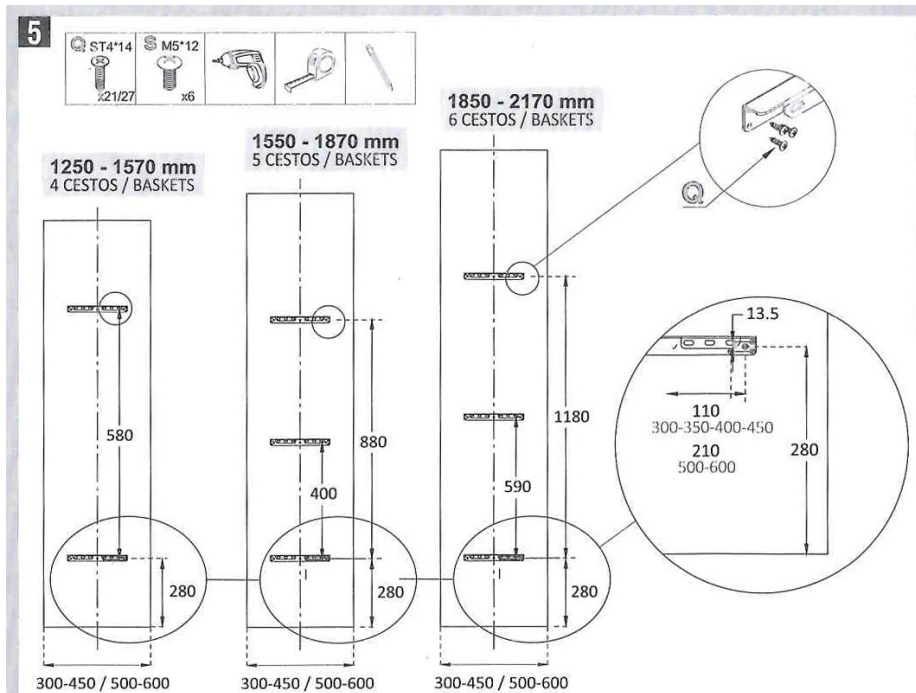
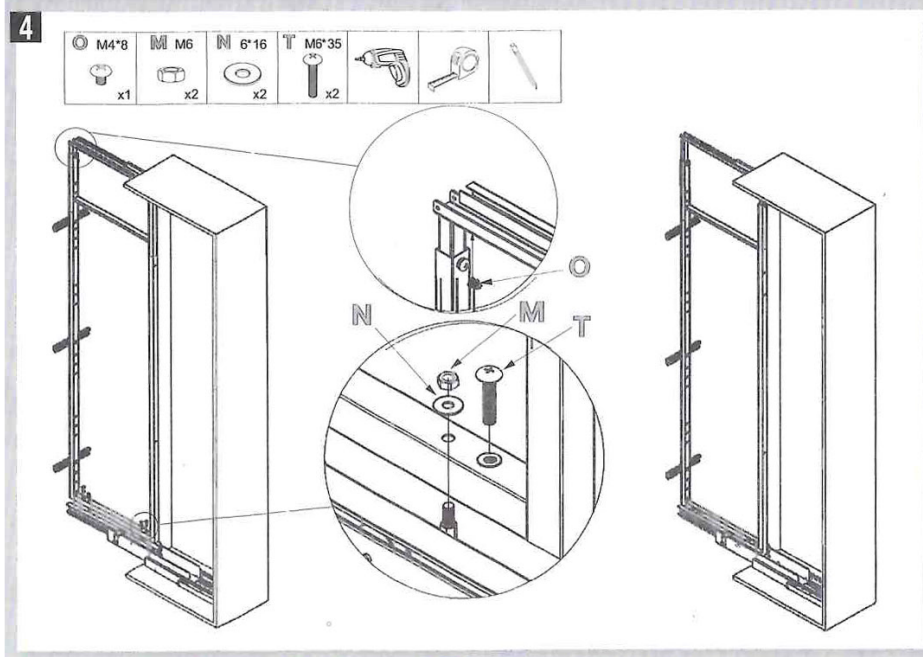
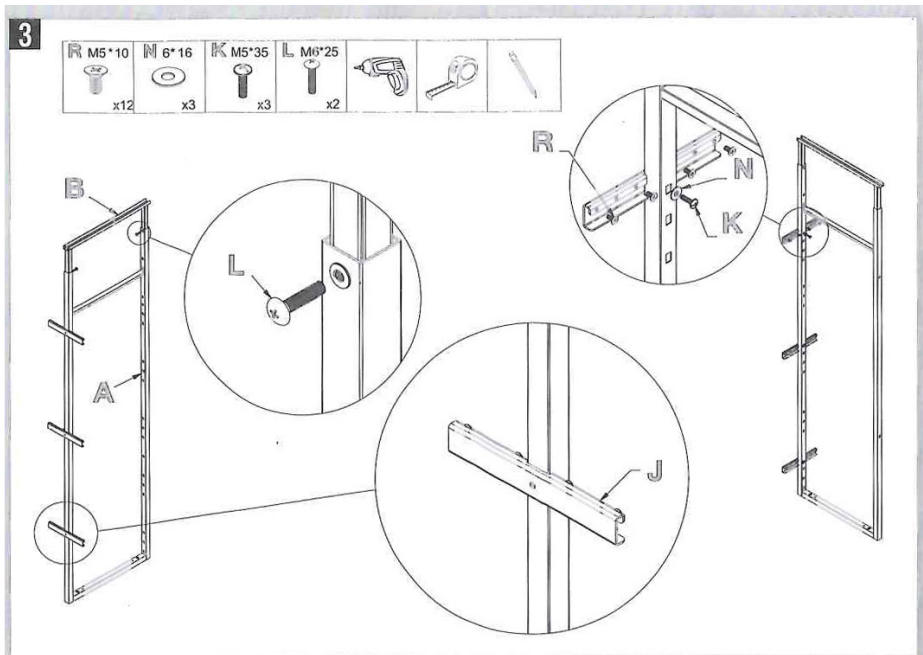

**6**

**1**

Aloje la parte K  
Ajuste la dirección superior e inferior de la puerta.

Loosen the part K  
Adjust the upper and lower direction of the door plate

**2**

Aloje la parte S al mismo tiempo.  
Ajuste la dirección izquierda y derecha de la puerta.

Loosen the part S at the same time.  
Adjust the left and right direction of the door plate

**3**

Aloje la parte S  
Ajuste la parte R para aflojar  
Ajuste la perpendicularidad izquierda y derecha de la puerta.

Loosen the part S  
Adjust the part R to loose  
Adjust the left and right perpendicularity of the door panel

**4**

Bloquear la parte L  
Ajuste la perpendicularidad delantera y trasera de la puerta.

Lock the part L  
Adjust the front and rear perpendicularity of the door panel.

Para cualquier movimiento e la guía inferior, aflojar el marco de la parte superior.  
For any movement of the lower guide, loosen the upper frame.

**7**

Bloquear la parte F después del ajuste.  
Lock part F after adjustment.

Colocar los enganches II  
Place the hooks II

**9**

Montar los cestos.  
Assemble the baskets.